

# Timber repairs

## Wood and water

Wood is hygroscopic: its cellulose molecules attract water. When wood is wet, water becomes absorbed within the cell wall structure and the wood swells. Similarly, wood shrinks as it dries.

Most swell or shrinkage occurs tangentially (around the circumference of the log), where it can be up to 12% of the original size, compared to up to 6% radially. The amount of swell or shrinkage also varies between

species and with different growth conditions. Boards cut tangentially (back-sawn or flat-sawn) will swell in width up to twice as much as boards cut radially (quarter-sawn) and are less suitable for use in exposed locations such as weatherboards. Fortunately, wood swells very little longitudinally (0.1%-0.2%), or it would have to be specially treated to be used for building or furniture.

### **Back-sawn and quarter-sawn timber**

*Back-sawn timber (tangentially cut) will swell and shrink in response to changes in moisture levels to a much greater degree than the radially cut, quarter-sawn timber.*

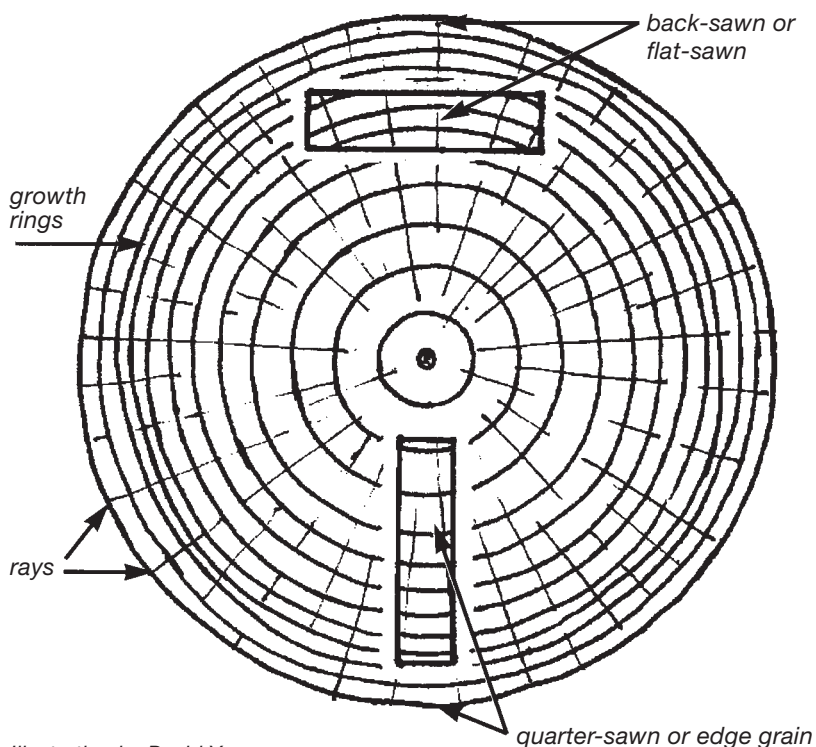

Illustration by David Young.

*This replacement lintel was green (unseasoned) when installed as part of repair works. It has now dried and shrunk, leaving a 20mm gap and unsupported brickwork above.*



*Photograph by David Young.*

*Replacing the rotten base of a post while retaining as much of the original as possible. Note the light outer sapwood and the darker heartwood of the new post base. The use of fungicidal rods and external 'bandages' should be considered when undertaking work such as this, particularly as the sapwood has no inherent durability. Posts not carrying a heavy structural load should not be set in concrete, but in free-draining gravel and earth.*



*Photograph by David Young.*

## The need for seasoning

Seasoning is the drying of green timber and is complete when the amount of moisture in the wood has reached equilibrium moisture content (EMC) with the surrounding air, normally about 10%-15% by weight for timber used internally. The EMC varies with humidity, being higher in humid coastal areas and lower in dry inland regions. Ensuring that replacement timber has a moisture content close to the local EMC will reduce the risk of the new timber swelling or shrinking after installation. For timber in use externally, EMC may be around 20%, approaching a level at which fungal growth is viable.

In normal use, seasoned wood swells or shrinks by 1%-2%. Greater movement than this leads to weakening of joints, and allows weather penetration through cracks, which promotes further deterioration.

## Wood repairs

Sometimes wood is so badly deteriorated that replacement of a section of timber is the only option. It is good conservation practice to replace the minimum necessary, and to do it with the traditional skills of the carpenter, joiner and cabinetmaker. The aim should be to reconstruct the original form of the damaged timber so that the repair does not detract from the appearance of the old work. Preferably, repairs should be done on site so that original fixings and fastenings are not lost.

To repair rotted timber and to be certain of removing all active fungi, remove the visible decayed zone together with any surrounding area affected. Apply fungicides to the remaining timber as a precaution.

## Synthetic repairs

There are occasions when sections of timber need strengthening. This might be because of fungal rot damage to the end of a timber beam, or the need to upgrade the structural capacity of the beam to enable a new use for the conserved building.

The real challenge comes when the beam is visible and is of some heritage value. An alternative to patching with timber is wood epoxy reinforcement (WER), which uses steel plates or steel or fibreglass rods as reinforcing. These are set into pre-cut slots or holes and bound to the remaining wood with epoxy resin. In most cases this can be achieved so that the reinforcing is not visible.

Synthetic resins can also be used to preserve non-structural timbers where the surface survives, such as a termite-damaged architrave with an original grained finish. After the termites are removed, resins such as acrylics or epoxies are injected into the wood to consolidate and strengthen it and so preserve the original finish. This type of work should be undertaken by an experienced conservator.

Epoxies give off considerable heat as they harden, the rise in temperature being proportional to the volume of material being used. It may be prudent to apply it in small quantities, with a cooling period between applications. Care needs to be taken not to set up new stresses in the timber, for example by converting a pin joint into a rigid joint by overuse of epoxy.

## Structural timber repairs

The complete removal and replacement of a failed timber member should be a last resort. Where the structure is concealed (as in a wall or roof space), a new member can be inserted beside the old one, or the old member can be patched with timber or strengthened by attaching steel bracing.

Where members are patched with timber, the strength of the joint is critical. The traditional scarf joint will resist most stresses in rafters, posts or beams, while a simpler halved joint can be used in wall plates. If the joint will be exposed to view, bolts can be concealed behind timber plugs.

Steel reinforcement can also be used with timber members. It may consist simply of steel plates either side of a member (or top and bottom), bolted through the timber. A method sometimes used for overstressed beams is to convert them to trussed girders by adding steel struts and tension rods underneath. Where space is not available for this, a variation using side rods is possible.

## Joinery repairs

Firstly, resist the temptation to repair every small knock or dent. Secondly, try to repair joinery on site wherever possible, as the process of removal and refitting inevitably results in further damage.

If decayed timber needs to be removed to form a splice or patch repair, take off just enough timber to allow an effective repair. Always fit the new material to the profile of the old.

### Traditional wedged scarf joint

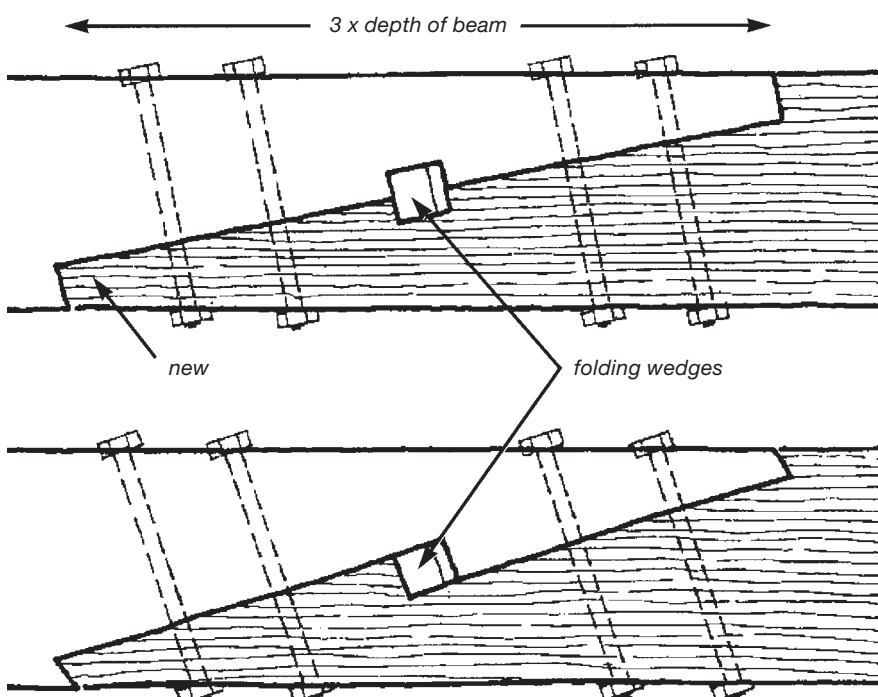

The timber species and moisture content of the new timber need to be carefully matched with the old to avoid differential movement. For clear-finished joinery, the colour and grain direction of the repair also need to be matched, and the new piece fitted to the old with a hairline joint.

Doors and windows typically suffer from rot at the base of the frame and door leaf or window sash, and also from loosening of joints. After any necessary patching of pieces which are beyond repair, the joints should be made tight by replacing wedges and regluing. On window sashes, minor decay combined with loose joints can often be repaired by removing the decay and repairing with epoxy, and using brass angle brackets let into the surface on the inner face.

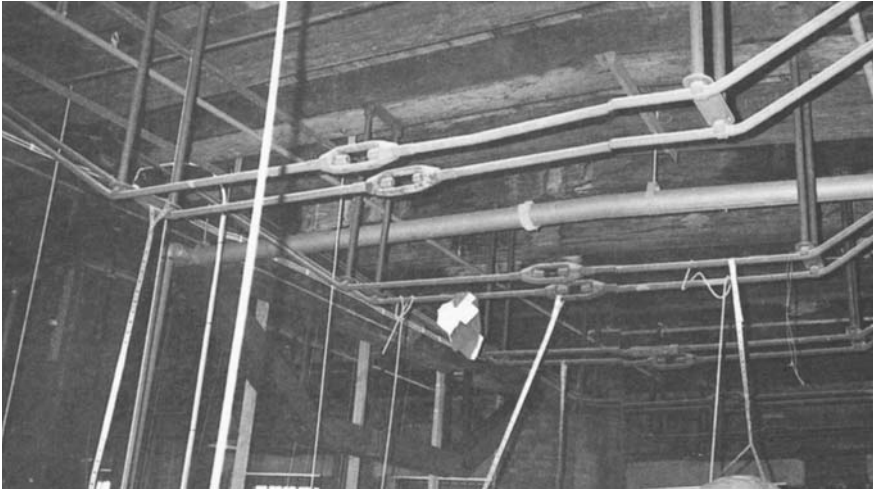

*Trussed girders used to strengthen beams at Walsh Bay wharves, Sydney.*

*Photograph by Peter Phillips.*

## Repairs using natural wood

Matching new pieces of wood to existing timber requires considerable skill. Correct species identification (refer to information sheet on Wood Preservation) is only the start. Other issues include:

- colour and grain matching (for clear-finished joinery)
- section sizes, especially for larger structural sections
- moisture content (see above)
- joint design.

## Recycled timber

Some of these problems may be overcome by using old timber. A number of firms specialise in the supply of old timber for repair of heritage structures. Great care should be taken in the selection of recycled timber to ensure that it does not contain defects or old fixings that will affect its use and durability. Also make sure that the timber is workable – some old well-seasoned hardwoods, notably ironbark, are very difficult to cut or drill.

When salvaging timber elements from a building or structure, take care to do so in a way which keeps the pieces usable.

Old nails have often rusted in the timber and cannot be punched out without taking a sizeable chunk of timber with them; it is better to cut the nails off. Removing floorboards carelessly can result in tongues being lost or edges split.

If second-hand timber used in repairs has not been salvaged from the site, it should be marked in some way to ensure that future investigators are not misled about its history.

**Strengthening beams using side tension rods**

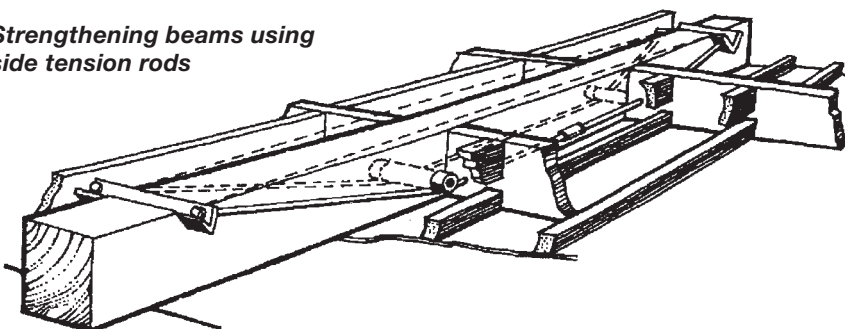

*Diagram from John MacGregor, Strengthening Timber Floors, SPAB, London.*

### Repairs to window sashes

Splayed splice joint with undercut and step to give optimum surface area for gluing/fixing and to ensure that moisture is directed away from vulnerable areas towards the outer face of the window.

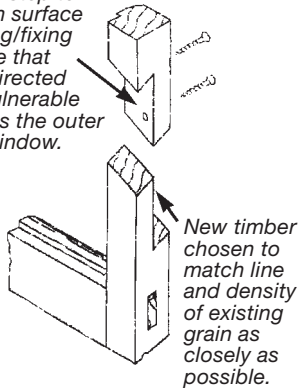

#### (i) Patching the bottom rail

Bracket let into (or fixed on surface of) timber on inner face of sash or casement

Brass angle bracket fixed with brass screws.

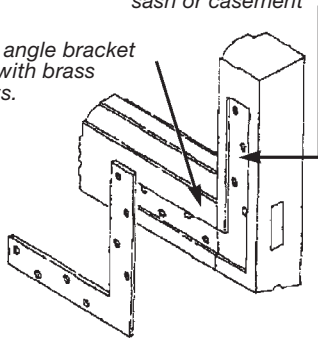

#### (ii) Reinforcing a loose corner with a brass angle

Diagram from A. Townsend & M. Martyn, *The Repair of Wood Windows*, SPAB, London.

## Commonly used timbers in heritage buildings and structures

The timber species used in early buildings often depended on the location of the site and the trees close at hand. Early hardwoods used in NSW included Blackbutt, Blue Gum, White Box, Red Box, Grey Box, Spotted Gum, Ironbark and Stringybark. Red Cedar (*Toona australis*) was very widely used.

### FURTHER READING

- Ashurst, J. & Ashurst, N. 1988, *Wood*, *Practical Building Conservation*, vol. 5, Wood, Glass and Resins, English Heritage Technical Handbooks, Gower Technical Press, Aldershot, Hants, UK.
- Bootle, K.R. 1983, *Wood in Australia: Types, Properties and Uses*, McGraw-Hill, Sydney.
- Phillips, M. W. & Selwyn, J.E. 1978, *Epoxies for Wood Repairs in Historic Buildings*, Technical Preservation Services Division, Heritage Conservation and Recreation Service, US Department of the Interior, US Government Printing Office, Washington, DC.
- Society for the Protection of Ancient Buildings, *The Repair of Timber Frames and Roofs*, by James Boutwood, Technical Pamphlet No.12, SPAB, London.
- Society for the Protection of Ancient Buildings, *The Repair of Wood Windows*, by A Townsend & M. Martyn, Technical Pamphlet No.13, SPAB, London.
- Society for the Protection of Ancient Buildings, *Strengthening Timber Floors*, by John MacGregor, Technical Pamphlet No. 2, SPAB, London.
- Standards Association of Australia 1995, *AS 3660.1-1995 Protection of Buildings from Subterranean Termites*, Standards Association of Australia, Sydney.
- Stumes, P. 1979, W.E.R. – *System Manual: Structural Rehabilitation of Deteriorated Timber*, Association for Preservation Technology, Ottawa.
- Warren Centre 1990, *Economic Recycling and Conservation of Structures: Technical Papers*, University of Sydney.
- Wilcox, W.W., Botsai, E.E. & Kubler, H. 1991, *Wood as a Building Material: A guide for Designers and Builders*, John Wiley & Sons, New York.

### DISCLAIMER

Any representation, statement, opinion or advice expressed or implied in this publication is made in good faith but on the basis that the State of New South Wales, its agents and employees are not liable (whether by reason of negligence, lack of care or otherwise) to any person for any damage or loss whatsoever which has occurred or may occur in relation to that person taking or not taking (as the case may be) action in respect of any representation, statement or advice referred to above.

ISBN 1 876415 81 9

HO 04/12